

SUPPORT BEARING DETAIL

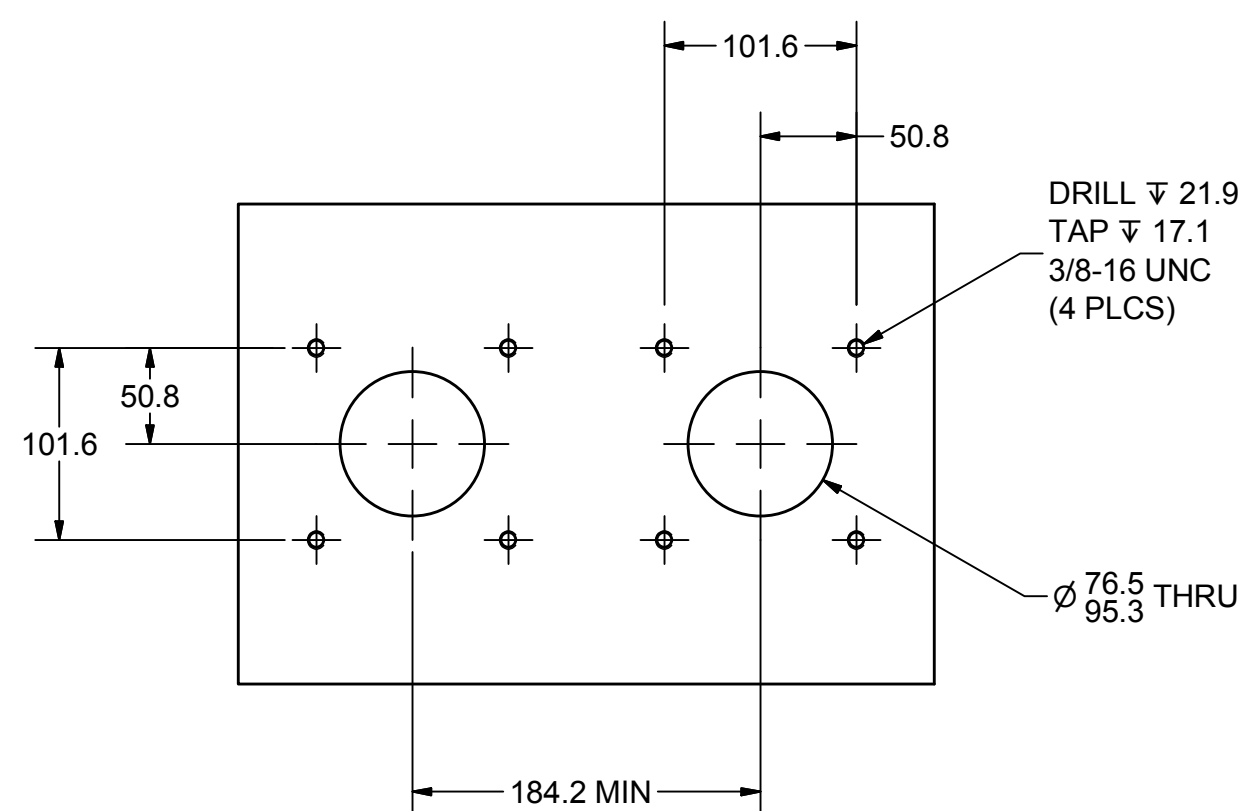
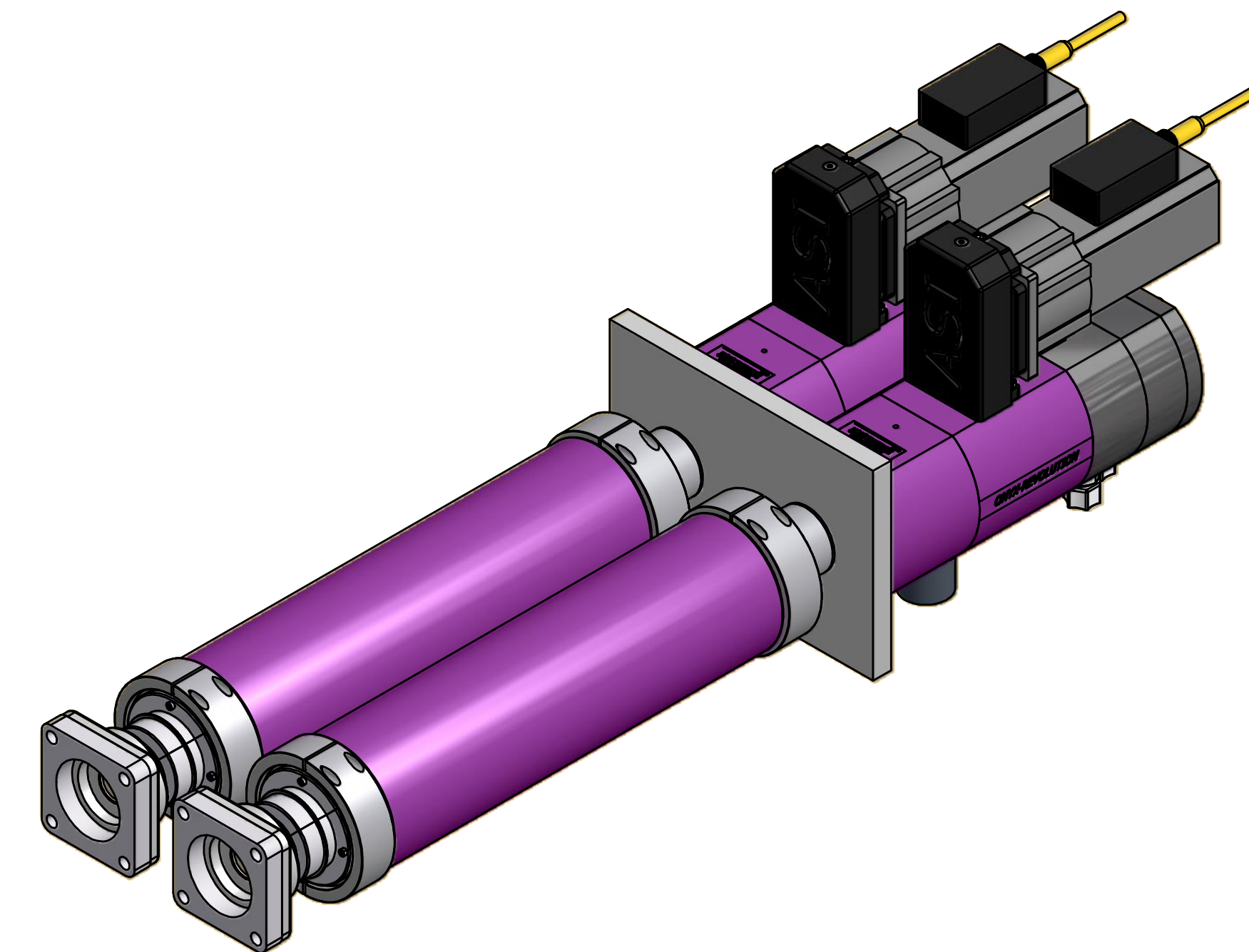
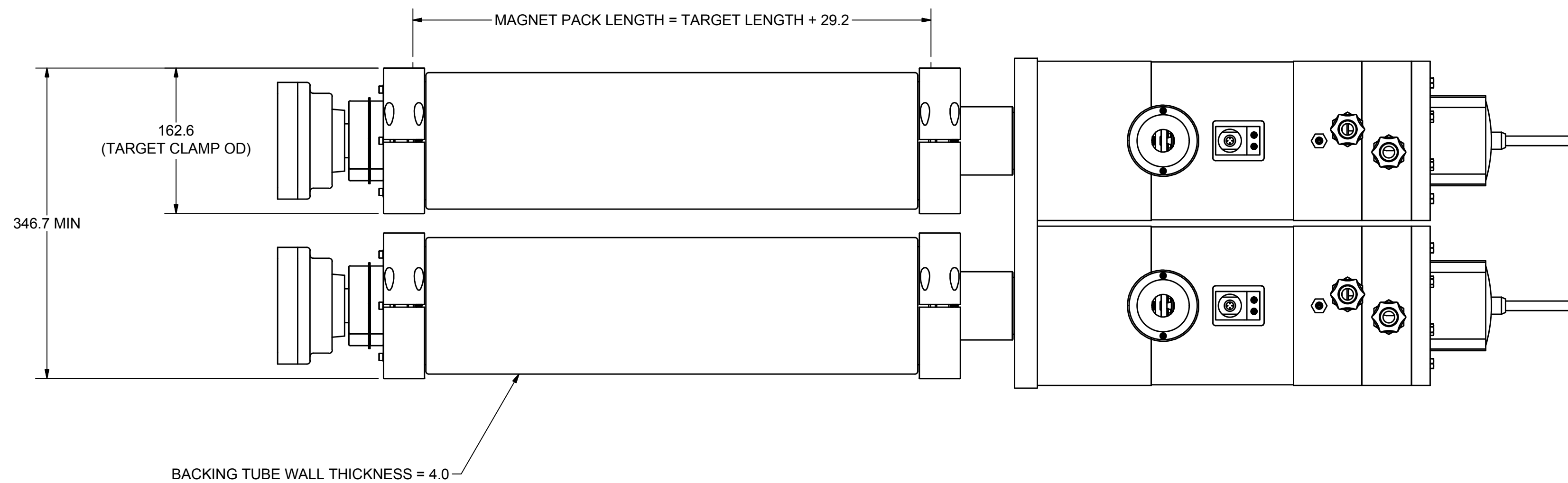
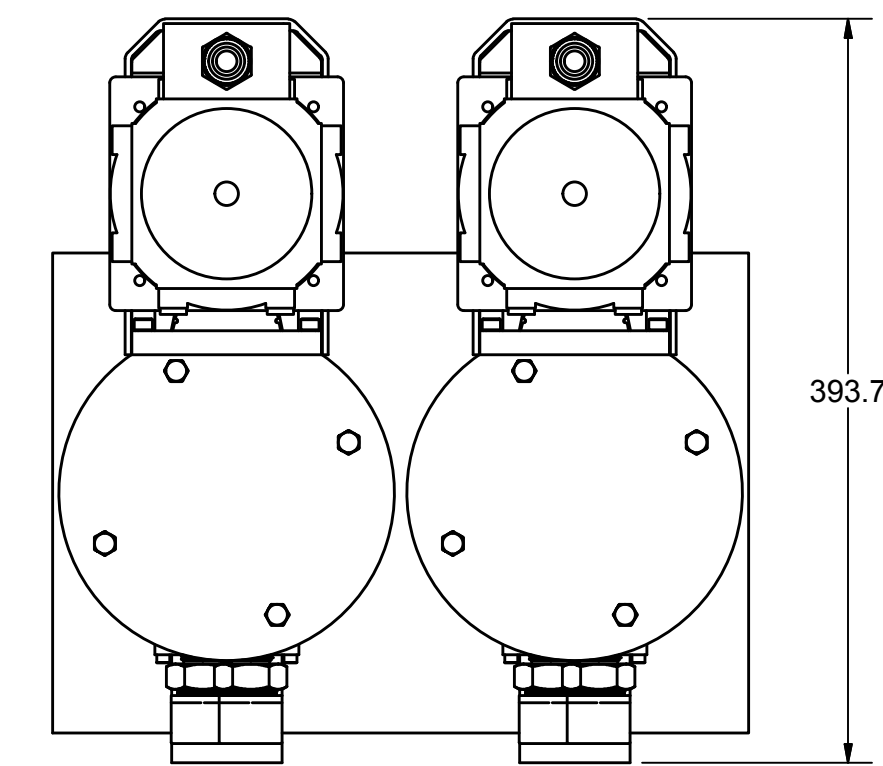
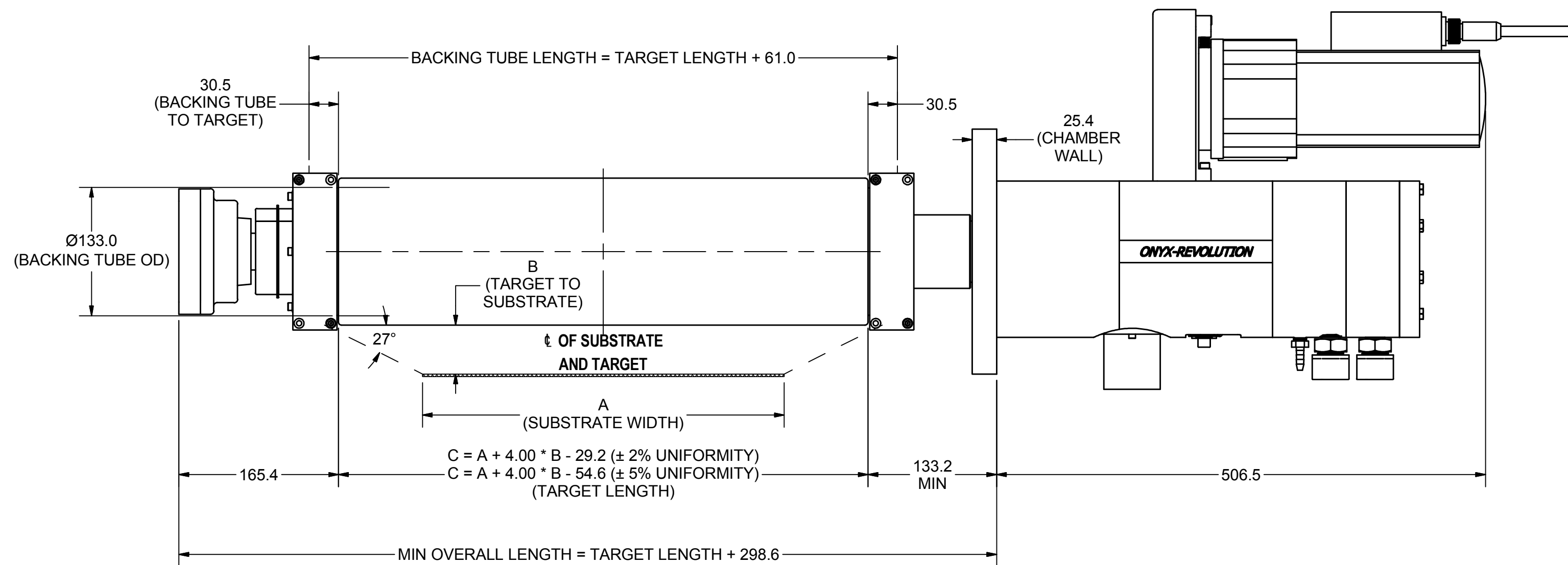

SEAL FACE DETAIL

REVOLUTION SIDE-MOUNT CYLINDRICAL - DUAL
UNITS: MM

NO.	DATE	REVISION	BY	TOLERANCES (UNLESS OTHERWISE SPECIFIED)	CONFIDENTIAL	SCALE: 1/4	ANGSTROM SCIENCES, INC.	
				LINEAR (IN.) FRACTIONAL = ± 1/64 2 PLACE DECIMAL = ± 0.01 3 PLACE DECIMAL = ± 0.005 4 PLACE DECIMAL = ± 0.0005	NOTICE: THE INFORMATION CONTAINED HEREIN IS PROPERTY OF ANGSTROM SCIENCES, INC. DUQUESNE, PA AND CONTAINS PROPRIETARY INFORMATION WHICH HAS BEEN SUBMITTED TO YOU IN CONFIDENCE FOR A SPECIFIC PURPOSE. COPYING, USING, OR DISCLOSING THIS DRAWING OR THE INFORMATION ON IT WITHOUT ANGSTROM SCIENCES' PRIOR WRITTEN CONSENT BY AN APPROVED REPRESENTATIVE IS PROHIBITED AND MAY BE GROUNDS FOR LEGAL ACTION. PATENTABLE DESIGN FEATURES ARE PROTECTED BY UNITED STATES PATENT LAWS.	DATE: 8/29/2017	TITLE:	
				ANGULAR DEGREES = ± 1° DECS. MINS = ± 00' 30"		DATE:	DRAWING NUMBER:	
S:\Angstrom Inventor\1-MAGNETRON\CYLINDRICAL\CONFIGURATOR FILES\CYLINDRICAL CATHODE DRAWINGS\COMPACT SIDE-MOUNT HORIZONTAL OR VERTICAL\DUAL\3800.idw						SHEET 1 OF 1	3800	
							REV. SIZE	D